

# Rozměry jednotky AQUAMI SERIES

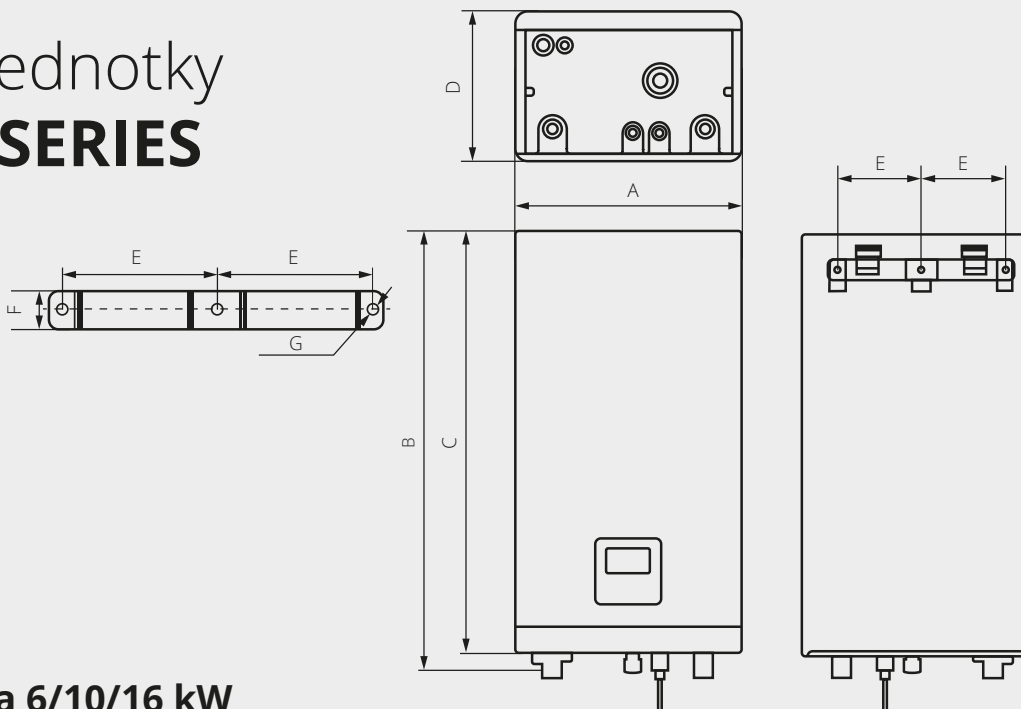

## Vnitřní jednotka 6/10/16 kW Rotenso Aquami Split

Model	Výkon	Rozměr (Š×H×V) [mm]	A	B	C	D	E	F	G	Hmotnost síť [kg]
AQ560X13i	6 kW	420 × 270 × 790	420	824	790	270	158	40	3 × Ø12	37
AQ5100X13i	10 kW	420 × 270 × 790	420	824	790	270	158	40	3 × Ø12	37
AQ5160X13i	16 kW	420 × 270 × 790	420	824	790	270	158	40	3 × Ø12	39

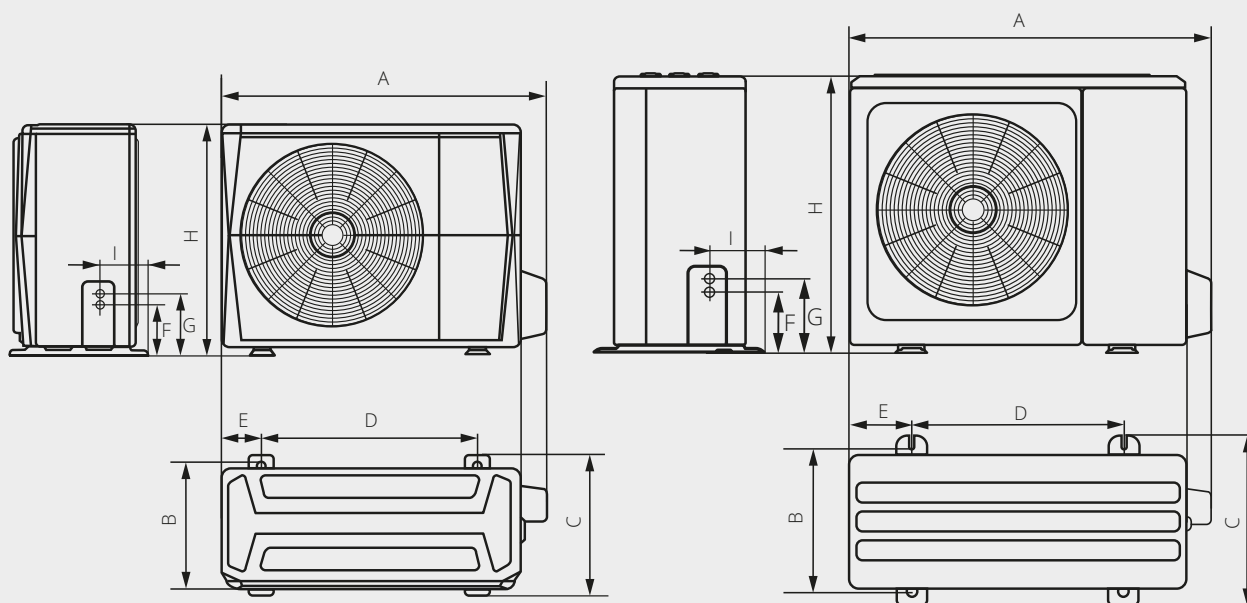

## Venkovní jednotka 4/6/8/10/12/14/16 kW Rotenso Aquami Split

Model	Výkon	Rozměry síť (Š×H×V) [mm]	Rozteč držáků (Š×H) [mm]	A	B	C	D	E	F	G	H	I	Hmotnost síť [kg]
AQ540X1o	4 kW	1008 × 426 × 712	663 × 375	1008	375	426	663	134	110	170	712	160	58
AQ560X1o	6 kW	1008 × 426 × 712	663 × 375	1008	375	426	663	134	110	170	712	160	58
AQ580X1o	8 kW	1118 × 523 × 865	656 × 456	1118	456	523	656	191	110	170	865	230	75
AQ5100X1o	10 kW	1118 × 523 × 865	656 × 456	1118	456	523	656	191	110	170	865	230	75
AQ5120X3o	12 kW	1118 × 523 × 865	656 × 456	1118	456	523	656	191	110	170	865	230	112
AQ5140X3o	14 kW	1118 × 523 × 865	656 × 456	1118	456	523	656	191	110	170	865	230	112
AQ5160X3o	16 kW	1118 × 523 × 865	656 × 456	1118	456	523	656	191	110	170	865	230	112